

Customized Photon Counting Module

PV- CM 9XZ / 13XZ /19XZ series

based on CPM Technology

Preliminary Datasheet

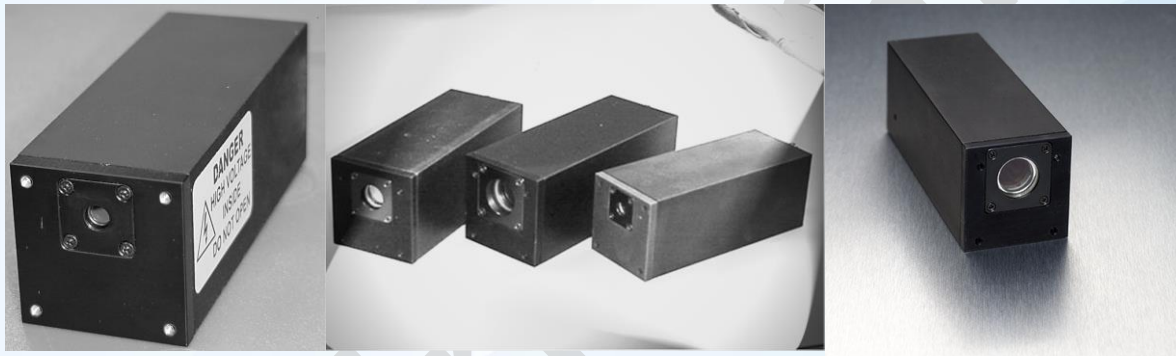

Single Photon Detection to 15 Megacounts/s
Spectral Range from UV to IR

APPLICATIONS

- ❖ Photon counting
- ❖ Luminescence & fluorescence spectroscopy
- ❖ Microplate readers
- ❖ Clinical diagnostics
- ❖ DNA & cell analysis
- ❖ Particle measurements
- ❖ Industrial spectroscopy
- ❖ Nucleic acid amplification (PCR)

FEATURES

- ❖ Extremely low background noise
- ❖ Best low light level detection limits
- ❖ High dynamic range & gain
- ❖ Low microphonic & magnetic sensitivity
- ❖ Compact size & rugged design
- ❖ Multiple photocathode and window selections
- ❖ Plug and play for shortest design-in and time-to-market
- ❖ Customizations and added features available

The Photon Counting Module series CM is designed for applications in all fields of single photon detection, e.g. chemoluminescence, bioluminescence, in-vitro assay, environmental measurements or pure research. It is an easy to use module, containing the Customized Photo Multiplier, a high voltage power supply, a discrimination amplifier and a pulse shaper for fast output pulses (TTL).

An installed active quenching system automatically avoids over-illumination to the detector. It is also possible to apply an external gate function for time correlated photon counting.

Strong variations in light levels are possible due to the high dynamic range of the installed CPM.



Typical output pulse of the CM series

The exceptional low noise and high sensitivity facilitates detection of extremely weak light levels. The modules can be equipped with various Customized Photo Multipliers in respect to spectral sensitivity and active area.

Count Rate Linearity

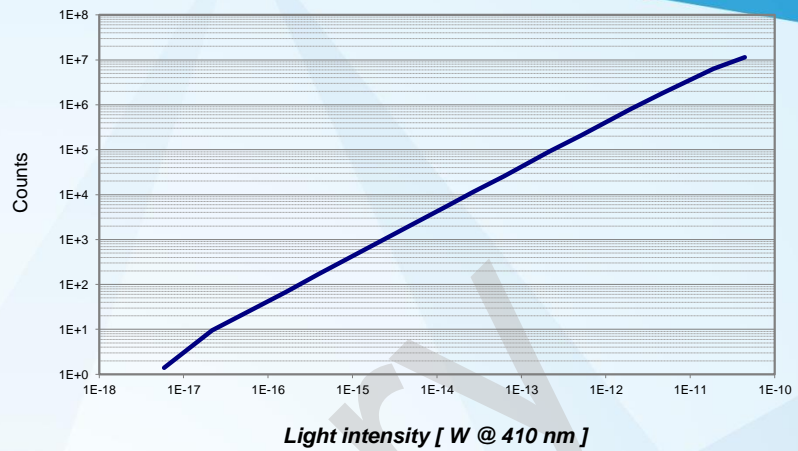

Module Specification

Linear count rate:	10 Mega Counts (20 Mcps max. count rate*)
Output Signal:	TTL-Pulse, positive
Over-illumination protection**):	Active quenching control (Gate enabled, no output signal) Reset: Via external TTL high or power supply switch off – switch on
Output impedance:	50 Ohms
Supply voltage	+5 V to +5.5 V DC
Gating (electronic shutter function)	TTL-Pulse, active high
Gate timing characteristics	Gate On (including Delay): 340 ns (typ.) Gate Off (including Delay): 180 ns (typ.)
Output pulse width	15 ns (typ), (optional: 130 ns, 300 ns)
Input current at max. count rate	< 250 mA
Maximum ratings	
Input voltage	+5.5 V
Operating temperature	+5 to +40 °C
Storage temperature	-20 to +50 °C
Weight	~ 350g / 420g / 450g (CM 9XZ / CM 13XZ / CM 19XZ)

*) for long term operation: max. average output countrate of < 100 Kcps (anode current of <100 nA) is recommended

**) Module will start counting only after external reset pulse or power off/on

List of Available Variations

Model (also order no.)	Detector type	Photocathode diameter	Photocathode material	Window material	Spectral response / nm	Quantum efficiency	Typ. dark counts per second (cps)	
CM 92B CM132B CM192B	Customized Photo Multiplier (CPM)	min. 5mm	Bialkali (B)	Quartz (2)	165-650	Peak value 20% typical (S25: 10% typ.)	10 40 100	
CM 93B CM133B CM193B			Bialkali (B)	UV Glass (3)	185-650		10 40 100	
CM 92E CM132E CM192E			S20 (E)	Quartz (2)	165-850		100 400 1000	
CM 93E CM133E CM193E			S20 (E)	UV Glass (3)	185-850		100 400 1000	
CM 92N CM132N CM192N			CM 13XZ	S25 (N)	Quartz (2)		165-900	500 2000 5000
CM 93N CM133N CM193N			min. 9mm	S25 (N)	UV Glass (3)		185-900	500 2000 5000
CM 92LB CM132LB CM192LB			CM 19XZ	Low Noise Bialkali (LB)	Quartz (2)		165-650	3 10 25
CM 93LB CM133LB CM193LB			min. 15mm	Low Noise Bialkali (LB)	UV Glass (3)		185-650	3 10 25
CM 92YE CM132YE CM192YE			Yellow Enhanced (YE)	Quartz (2)	165-750		10 40 100	
CM 93YE CM133YE CM193YE			Yellow Enhanced (YE)	UV Glass (3)	185-750		10 40 100	

PV_CM_PhotonCountingModule_201611.docx
Subject to change without notice

Spectral response of various CPM types

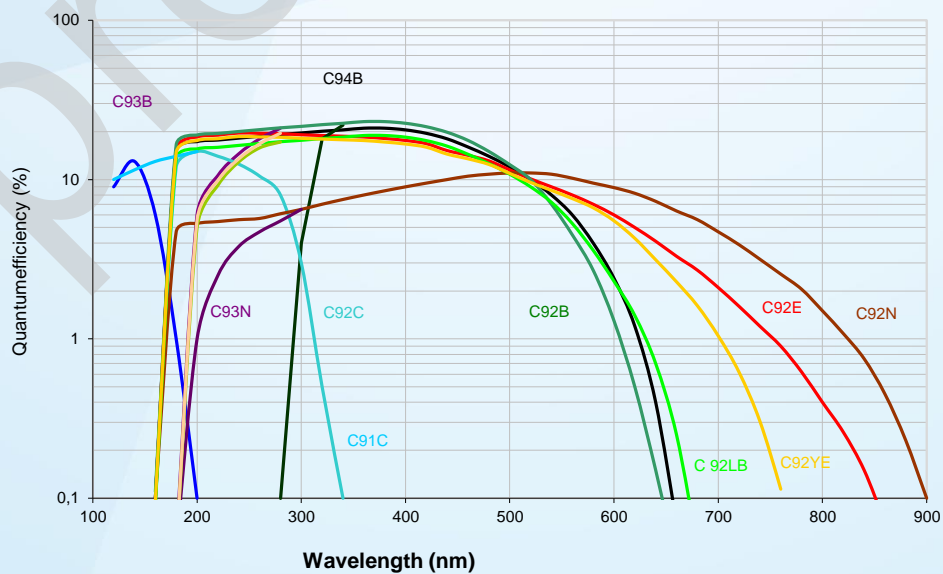

Module Dimensions (mm) for Different CPM Formats

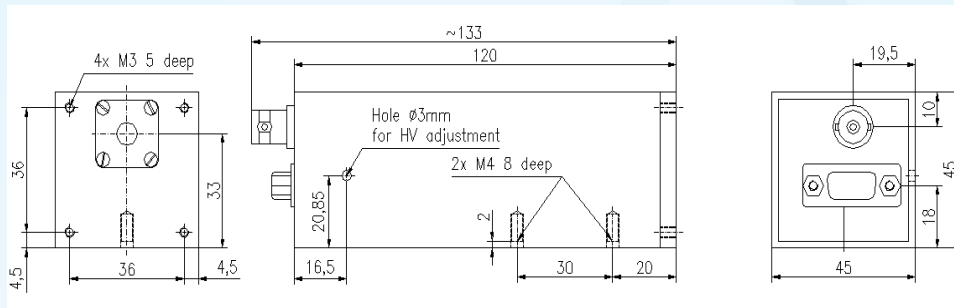

PV- CM 9XZ

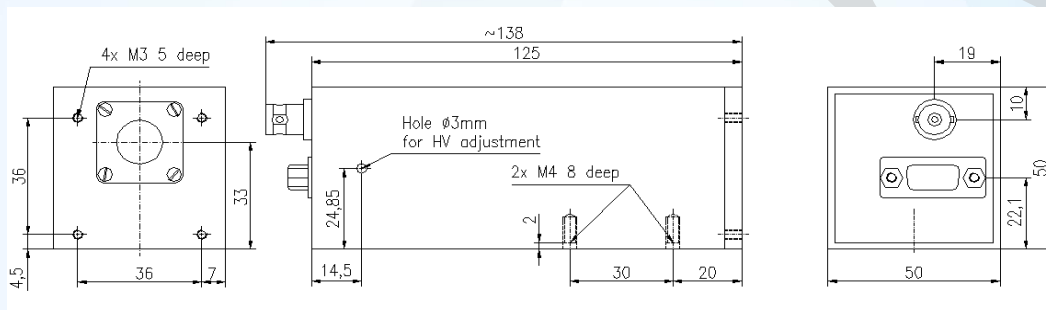

PV- CM 13XZ

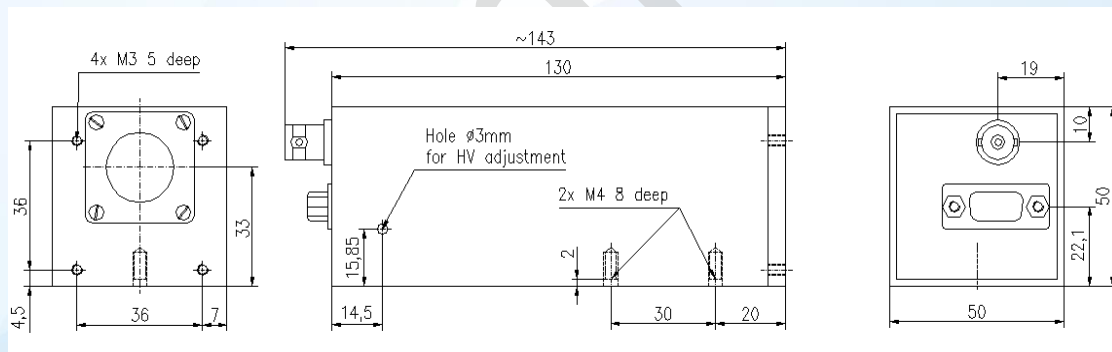

PV- CM 19XZ

PV_CM_PhotonCountingModule_201611.docx
Subject to change without notice

<i>Window Material X for</i>		<i>Photocathode Type Z for</i>	
MgF ₂	=1	Cesium Iodid	=CI
Quartz	=2	Cesium Tellurid	=C
UV-Glass	=3	Bialkali	=B
Borosilicat	=4	LowNoise Bialkali	=LB
		S20	=E
		S25	=N
		YellowEnhanced	=YE